

Use and Care Guide

F&P SleepStyle+ Auto
F&P SleepStyle+ CPAP



English

LANGUAGES

LANGUAGE

SECTION

English

A

BEFORE YOU START

Before the device is used for the first time, it must be set up by a healthcare provider.

If your device or any accessories are not operating correctly, please contact your healthcare provider.

Healthcare providers: please contact your Fisher & Paykel Healthcare representative for a copy of the *F&P SleepStyle+ Clinician Guide*.

TABLE OF CONTENTS

1. Overview	A-3
1.1 Intended use	A-3
1.2 Contraindications	A-3
1.3 Warnings	A-3
1.3.1 To avoid death or serious injury	A-3
1.3.2 To avoid electric shock.....	A-3
1.3.3 To avoid burns	A-3
1.3.4 To avoid the risk of fire.....	A-3
1.3.5 To avoid the risk of fire with supplemental oxygen.....	A-4
1.3.6 To avoid carbon dioxide re-breathing or asphyxiation	A-4
1.3.7 To avoid choking, or inhalation of a foreign object	A-4
1.3.8 To avoid injury.....	A-4
1.3.9 To avoid incorrect therapy	A-4
1.3.10 General	A-4
1.4 Cautions.....	A-5
1.4.1 To prevent water damage to the device.....	A-5
1.4.2 General	A-5
1.5 Precautions.....	A-5
1.6 Side effects.....	A-5
2. Getting started	A-6
2.1 Device and accessories	A-6
2.2 Setting up your device.....	A-7
2.3 Setting up your device with supplemental oxygen.....	A-9
3. Using your device	A-10
3.1 Screen icons	A-10
3.2 Device controls.....	A-10
3.3 Starting therapy.....	A-11
3.4 Stopping therapy	A-11
3.5 Stand-by mode.....	A-11
3.6 Comfort settings	A-11
3.6.1 Ramp.....	A-11
3.6.2 Humidity	A-11
3.6.3 Expiratory relief.....	A-12
3.6.4 SensAwake™.....	A-12
3.6.5 Auto Start / Stop.....	A-12

4. Viewing your therapy data	A-12
4.1 View your therapy data on your device.....	A-12
4.1.1 Therapy Data.....	A-12
4.2 View your therapy data on the SleepStyle App.....	A-13
5. Uploading your therapy data	A-14
5.1 Modem	A-14
5.2 F&P InfoUSB™.....	A-14
5.2.1 InfoUSB application.....	A-15
6. Caring for your device	A-16
6.1 Disassembly for cleaning.....	A-16
6.2 Cleaning your device and accessories at home.....	A-16
6.2.1 Wash after each use.....	A-17
6.2.2 After 7 days' use.....	A-17
6.3 Reassembly of the device.....	A-18
6.4 Replacement parts	A-18
6.4.1 Air filters.....	A-19
7. Traveling with your device	A-19
8. Specifications	A-20
8.1 SleepStyle+ device models and features	A-20
8.2 Symbol definitions.....	A-20
8.3 Product specifications.....	A-21
8.4 Classifications.....	A-24
8.5 Operating conditions.....	A-24
8.6 Storage and transport conditions	A-24
8.7 Disposal instructions.....	A-24
8.8 Servicing.....	A-24
8.9 Warranty statement.....	A-24
9. Troubleshooting	A-25
9.1 Device troubleshooting.....	A-25
9.2 Error messages on SleepStyle+ screen.....	A-27

1. OVERVIEW

WELCOME

Thank you for choosing your F&P SleepStyle+ device.

The F&P SleepStyle+ Auto is an auto-adjusting positive airway pressure device.

The F&P SleepStyle+ CPAP is a continuous positive airway pressure (CPAP) device.

This guide refers to the F&P SleepStyle+ Auto and F&P SleepStyle+ CPAP as the “device”. The device is intended to treat Obstructive Sleep Apnea (OSA) by delivering a flow of positive airway pressure (PAP) at a level prescribed by the physician, to splint open the airway and prevent airway collapse.

Please read this guide carefully before you use your device. Keep this guide in a safe place so you can refer to it later if you need to.

1.1 INTENDED USE

The device is for use on adult patients for the treatment of Obstructive Sleep Apnea (OSA).

The device is for use in the home or sleep laboratory.

1.2 CONTRAINDICATIONS

Warnings

Subject to your physician's oversight, PAP therapy may be contraindicated for those with any of the following pre-existing conditions:

- Cerebrospinal fluid leak
- Abnormalities of the cribriform plate
- Pneumocephalus
- Pneumothorax
- Hypotension
- Gastrointestinal bleeding or ileus
- Excess production or retention of secretions in the respiratory tract
- Severe hypoxemia or acidosis
- Impaired consciousness

Caution should be exercised when prescribing or resuming use of PAP therapy for those who have recently experienced any of the following:

- Facial or cranial surgery or trauma
- Respiratory or cardiac arrest
- Gastrointestinal surgery

If you are unsure about what pre-existing conditions you have, check with your physician or healthcare provider.

1.3 WARNINGS

1.3.1 To avoid death or serious injury:

- The device must only be used on adult patients.
- The device must only be used for the treatment of OSA.
- The device must only be used on prescription by a physician.
- The device must not be used for life-support applications.

1.3.2 To avoid electric shock:

- Do not use if the device, power cord or accessories are damaged, deformed, or cracked.
- Do not pull on the power cord as it may become damaged.
- Do not use bleach, alcohol, or cleaners with citrus or other natural oils. These substances may degrade the device and accessories.
- Do not immerse the device in water or any other liquid.
- Do not modify the device or accessories.
- Do not take apart the device. Taking the device apart, for example by unscrewing the underside of the device, will damage pressure seals and electrical components.

1.3.3 To avoid burns:

- Do not lie on, and avoid prolonged skin contact with, the ThermoSmart™ breathing tube.
- Do not fill the water chamber with hot water as this may lead to airway burns.
- Do not introduce into or operate the device or accessories in a magnetic resonance (MR) environment as there is a risk of burns due to electromagnetic effects.

1.3.4 To avoid the risk of fire:

- Do not cover the ThermoSmart breathing tube as this may overheat the tube.
- Do not connect electrical accessories not approved for use with the device.

1.3.5 To avoid the risk of fire with supplemental oxygen:

- Turn on therapy on the device prior to turning on the oxygen supply. Turn off oxygen supply before turning off therapy on the device. If oxygen is left on, it can accumulate inside the device and create a fire risk.
- Ensure adequate ventilation is provided around the device.
- Remove any source of ignition, such as cigarettes, an open flame, or materials which burn or ignite easily at high oxygen concentration.
- Do not smoke when using supplemental oxygen.
- Keep oxygen regulators, cylinder valves, tubing, connections and all other oxygen equipment away from oil, grease or greasy substances. Spontaneous and violent ignition may occur if these substances come into contact with oxygen under pressure.

1.3.6 To avoid carbon dioxide re-breathing or asphyxiation:

- Do not use masks that do not contain a vent suitable for CPAP therapy, or are not recommended by Fisher & Paykel Healthcare or your healthcare provider.
- Remove the mask immediately if the device is powered off (including in the event of a power failure or device malfunction). The flow through the mask may be insufficient to clear all exhaled gas.

1.3.7 To avoid choking, or inhalation of a foreign object:

- Ensure the breathing tube and power cord, including any extension cords, are correctly positioned so they will not become entangled with the body or furniture during sleep.
- Do not use the device without the recommended air filter fitted. The air filter will reduce dust or particles entering the device and breathing tube.
- Do not place the device above head height to prevent water from entering the breathing tube.
- Do not use the device with water in the water chamber if the device is being used in a moving vehicle or ship.

1.3.8 To avoid injury:

- Do not place the device above head height as the device may fall.
- Do not use breathing tubes, parts and accessories that are not distributed for use with this device or recommended by Fisher & Paykel Healthcare.
- Do not use the breathing tubes or accessories with any other device.
- Do not use ozone or activated oxygen to clean this device. Residual ozone may result in adverse respiratory effects such as irritation of the nose, throat and lungs.
- This device contains a non-replaceable lithium coin cell battery that is hazardous. Keep away from children. Seek immediate medical attention if it is suspected the button cell battery has been swallowed or placed inside any part of the body, as severe or fatal injuries may occur within 2 hours.

1.3.9 To avoid incorrect therapy:

- Do not cover the device or place it where the air inlet could be obstructed (such as next to curtains).
- Do not use the device adjacent to electrical equipment.
- Do not adjust the pressure. Pressure adjustments should only be made by a qualified healthcare provider.
- Refer to the mask's *Use and Care Guide* prior to use to ensure correct fit of the mask. Incorrect fit of the mask may affect consistent operation of this device.
- Only clean the device and accessories according to the cleaning instructions set out in section 6 – *Caring for Your Device*.
- Do not clean or disinfect the ThermoSmart breathing tube with hot water. This may cause deformation of the tube and reduce therapeutic pressure.
- Use the elbow when rotating the ThermoSmart breathing tube. Incorrect handling may damage the tube.
- Do not remove the InfoUSB, or power off the device, before you see this screen when updating your prescription using InfoUSB:

**Prescription
updated**

Press any button to acknowledge and clear this message.

1.3.10 General:

- Only use the device within the operating conditions specified, otherwise the performance of the device could be compromised. See section 8.5 – *Operating Conditions*.
- Do not place any part of the device or accessories within 30 cm (12 in.) of any portable mobile radio frequency communication equipment. The device complies with the electromagnetic compatibility requirements of IEC 60601-1-2 and the device may affect or be affected due to the effects of electromagnetic interference, in certain circumstances. If interference should occur, try moving your device or the equipment causing interference. Alternatively, consult your healthcare provider.
- Do not use accessories or power cables which are not provided, or recommended, by Fisher & Paykel Healthcare. This could result in increased electromagnetic emissions or decreased electromagnetic immunity.
- This device is not repairable and does not contain any repairable parts. Please refer queries relating to the device or accessories to your healthcare provider.
- To avoid contamination with infectious agents, do not share the device, or any used associated spares and consumables, with other patients.

1.4 CAUTIONS

1.4.1 To prevent water damage to the device:

- Do not use if the water chamber is damaged.
- Do not fill the chamber housing with water. Only place water in the water chamber.
- Do not fill the water chamber above the maximum water-level line.
- Replace water before each use.
- Do not use the device without the chamber seal fitted to the water chamber.
- Do not fill the water chamber while it is in the device.
- Empty the water chamber before transporting or packing the device.
- Do not use the device with an empty water chamber unless the humidity level is set to 0.
- Do not add aromatic-based or scented oils to the water chamber as these oils can cause damage to the device.

1.4.2 General:

- Changes or modifications not expressly approved by Fisher & Paykel Healthcare voids the user's authority to operate the device.
- Position the device so the power cord connection to the power supply is easily accessible and able to be disconnected.
- Do not use USB drives with the device which are not provided by Fisher & Paykel Healthcare. Use of USB drives other than the InfoUSB may cause data corruption. Do not attempt to change the directories or view the data without software distributed or designed for use with the device.
- Replace the device and accessories if there are any signs of cracking, deformation, discoloration or leaking. It is recommended that you inspect the device, breathing tube, water chamber, chamber seal, outlet seal, air filter and elbow, on a regular basis after cleaning. See section 6.4 - *Replacement Parts*.
- Use distilled water to reduce residue build-up on the chamber base. This will extend the life of your water chamber.
- Do not use ozone or activated oxygen to clean the device as it can degrade the device and its accessories.

1.5 PRECAUTIONS

- The safety and effectiveness of the continuous positive airway pressure (CPAP) device has not been established in patients with respiratory failure or chronic obstructive pulmonary disease (COPD).
- The safety and effectiveness of the auto-adjusting positive airway pressure device has not been established in patients with congestive heart failure, obesity hypoventilation syndrome, or central sleep apnea.

1.6 SIDE EFFECTS

- Difficulty sleeping, bloating or belching, dizziness or nausea, shortness of breath, facial skin dryness or roughness, dry mouth, sore throat, runny nose, nosebleed, blocked or itchy nose, or sinus pain.
- These side effects may subside over time with continued PAP therapy use, but if they are unduly intrusive to your daily life or prevent you from complying with your prescribed treatment plan, please consult your medical device provider or a healthcare professional.

2. GETTING STARTED

2.1 DEVICE AND ACCESSORIES

- 1 x Carry bag
- 1 x SleepStyle+ device
- 1 x Breathing tube
- 1 x Power cord
- 1 x F&P SleepStyle+ Use and Care Guide
- 1 x F&P SleepStyle+ Quick Reference Guide
- 1 x Water chamber

- 1 x Chamber seal
- 1 x Outlet seal
- 1 x F&P InfoUSB (already in InfoUSB port)
- 1 x Air filter (already in the device)
- 1 x Spare air filter
- 1 x Spare elbow (for use with a standard breathing tube)

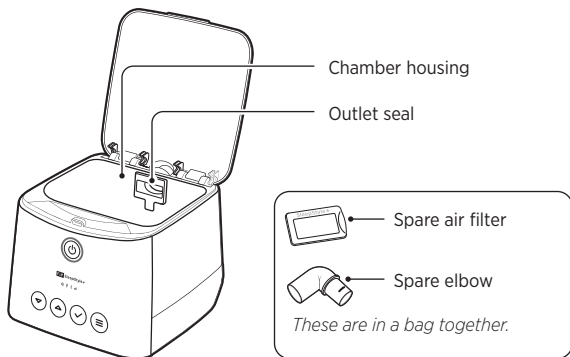
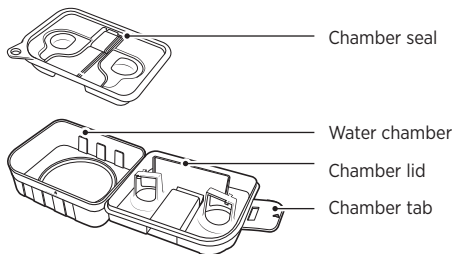
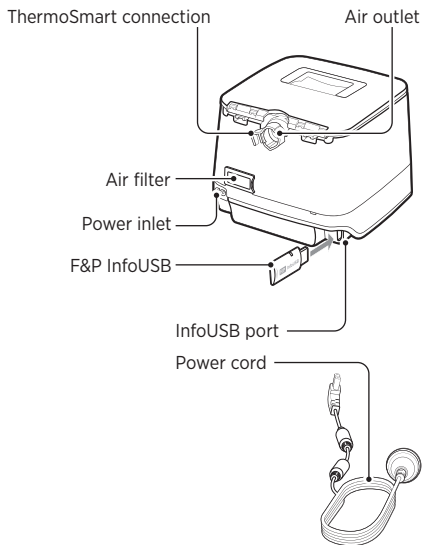
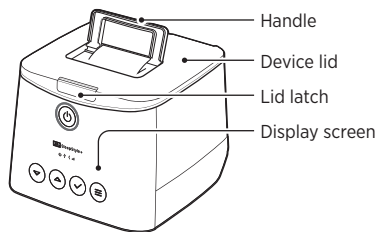

ThermoSmart breathing tube **or** standard breathing tube with elbow

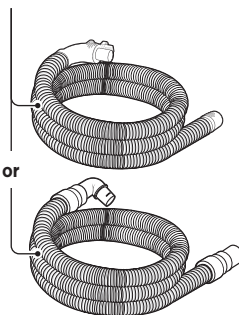

2.2 SETTING UP YOUR DEVICE

1. Place the device below head height on a stable and level surface, like a bedside table.

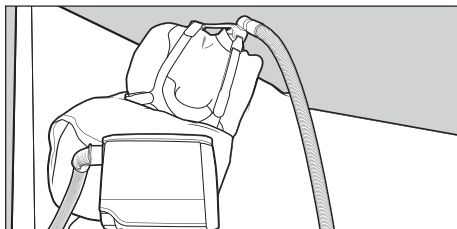

⚠ Warnings

To avoid injury, choking, inhalation of a foreign object and to prevent water from entering the tube: Do not place the device above head height.

2. Connect the power cord and the breathing tube.

Connect the power cord into the power inlet of the device. Connect the other end of the power cord into a power outlet.

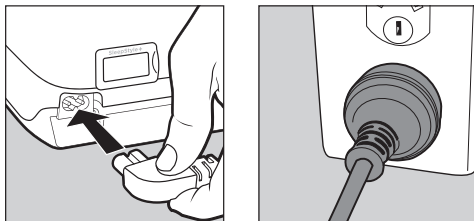

⚠ Warnings

To avoid electric shock:
Do not use if the device, power cord, or accessories are damaged, deformed or cracked.

To avoid choking, or inhalation of a foreign object:
Ensure the breathing tube and power cord, including any extension cords, are correctly positioned so they will not become entangled with the body or furniture during sleep.

Breathing tube

Connect your breathing tube into the air outlet.

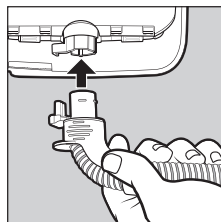

ThermoSmart breathing tube

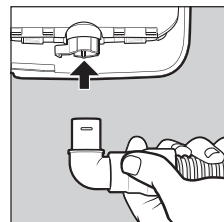

Standard breathing tube

Note: Make sure the connectors on the ThermoSmart breathing tube click into position with the ThermoSmart connection.

If you have connected the ThermoSmart breathing tube correctly, the ThermoSmart icon  will appear on your home screen.

⚠ Warnings

To avoid incorrect therapy:
Use the elbow when rotating the ThermoSmart breathing tube. Incorrect handling may damage the tube.

3. Remove the water chamber from the device.

Press the lid latch and open the device lid. Take the water chamber out of the device.

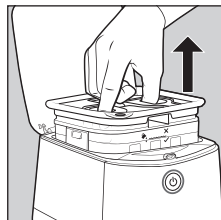
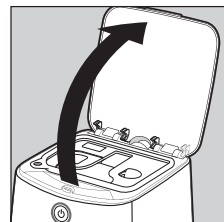
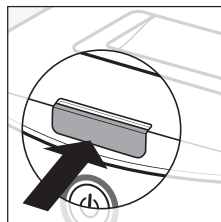

4. Fill the water chamber with water.

Fold back the chamber seal using the corner tab. Fill the water chamber with water up to the maximum water-level line, as indicated on the side and inside of the water chamber.

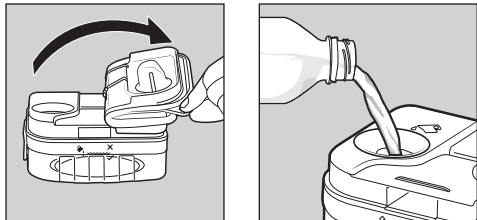

⚠ Warnings

To avoid burns:

Do not fill the water chamber with hot water as this may lead to airway burns.

⚠ Cautions

To prevent water damage to the device:

- Do not use if the water chamber is damaged.
- Do not fill the chamber housing with water. Only place water in the water chamber.
- Do not fill the water chamber above the maximum water-level line.
- Replace water before each use.
- Do not fill the water chamber while it is in the device.
- Do not use the device with an empty water chamber unless the humidity level is set to 0.
- Do not add aromatic-based or scented oils to the water chamber as these oils can cause damage to the device.

General:

Use distilled water to reduce residue build-up on the chamber base. This will extend the life of your water chamber.

5. Secure the chamber seal.

Unfold the chamber seal back onto the water chamber. Push down on the finger holds to secure it in place.

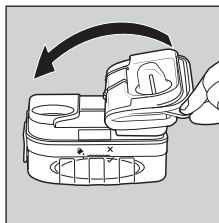

⚠ Cautions

To prevent water damage to the device:

Do not use the device without the chamber seal fitted to the water chamber.

6. Put the water chamber back into the device.

Place the water chamber back into the device. Push the device lid down until the lid latch clicks into position.

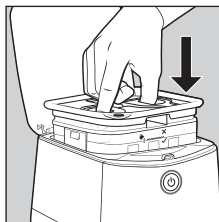

7. Connect the mask to the breathing tube.

Holding the mask and the other end of the breathing tube, connect the mask swivel firmly into the breathing tube.

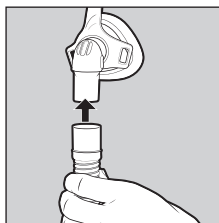

2.3 SETTING UP YOUR DEVICE WITH SUPPLEMENTAL OXYGEN

Supplemental oxygen can be administered at the mask end of the breathing tube up to a maximum flow rate of 5 litres per minute as follows:

1. Set up the device by following steps 1 - 6 of section 2.2 - *Setting up your device.*

2. Connect the Oxygen/Pressure Port Connector 900HC452 between the mask swivel/inlet and the breathing tube outlet.

3. Connect the oxygen tube to the Oxygen/Pressure Port Connector 900HC452.

Refer to diagram below:

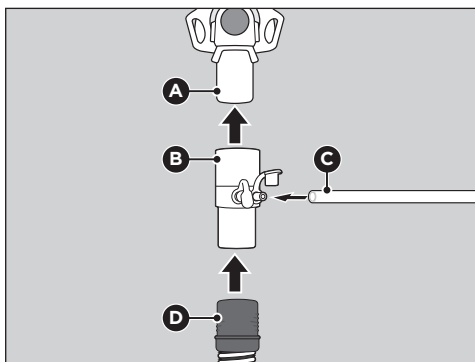

A. Mask Swivel/Inlet

B. Oxygen/Pressure Port Connector 900HC452

C. Oxygen Tube

D. Breathing Tube Outlet

Refer to the Oxygen/Pressure Port Connector 900HC452 User Instructions for more information including cleaning.

⚠ Warnings

To avoid risk of fire with supplemental oxygen:

- Turn therapy on the device prior to turning on the oxygen supply. Turn off the oxygen supply before turning off therapy on the device. If the oxygen is left on, it can accumulate inside the device and create a fire risk.
- Ensure adequate ventilation is provided around the device.
- Remove any source of ignition, such as cigarettes, an open flame, or materials which burn or ignite easily at high oxygen concentration.
- Do not smoke when using supplemental oxygen.
- Keep oxygen regulators, cylinder valves, tubing, connections and all other oxygen equipment away from oil, grease or greasy substances. Spontaneous and violent ignition may occur if these substances come into contact with oxygen under pressure.

Notes:

- Ensure there is no obstruction downstream of the Oxygen/Pressure Port Connector 900HC452 as this can affect the delivered oxygen concentration.
- At a fixed flow rate of supplemental oxygen, the inhaled oxygen concentration will vary, depending on the pressure settings, the patient's breathing pattern, mask selection and leak rate.
- It is recommended that the oxygen concentration is measured at the point of delivery to the patient.

3. USING YOUR DEVICE

3.1 SCREEN ICONS

When your device is plugged in and switched on, you will see the home screen appear with up to four icons. These icons indicate the status of a setting or accessory, as follows:



ThermoSmart Icon

Indicates that the ThermoSmart breathing tube is connected and working correctly



InfoUSB Icon

Indicates that the F&P InfoUSB is connected and working correctly



Bluetooth® Icon*

Indicates that Bluetooth technology is turned “ON” on your device and is working correctly



Modem Icon*

Indicates that modem is turned “ON” on your device and is working correctly

Note: If there is a line through one of these icons, or if there is a gap where an icon usually appears, refer to section 9.1 – Device Troubleshooting for more information.

* Not available in all models.

3.2 DEVICE CONTROLS

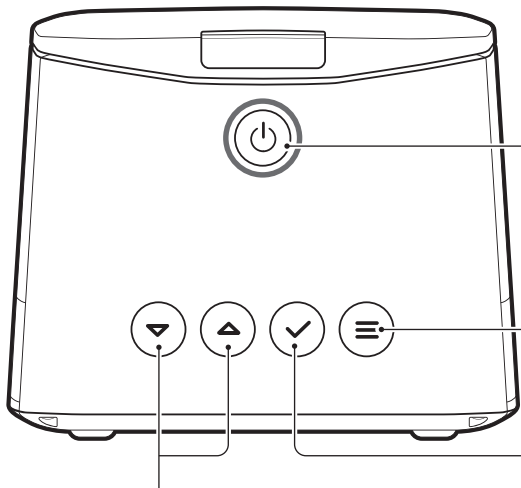

Start/Stop

- Press to start and stop therapy.
- Press and hold for 3 seconds to start Ramp.

Menu

- Press to enter the Menu at any time.
- Press to scroll between settings or data screens.

Down and Up

- Press to decrease or increase a comfort setting.
- Press to move between options in a setting.
- Press to show the “Humidity” setting at any time.

OK

- Press to make a selection.
- Press to accept an instruction on the display screen.

3.3 STARTING THERAPY

1. Fit your mask.

Note: Refer to your mask's user instructions for more information on how to fit and remove your mask.

2. Press Start/Stop to begin therapy.

The screen below will appear:



Note: If Auto Start/Stop is activated, the device will automatically start therapy whenever you breathe into your mask.

If using supplemental oxygen, turn on the oxygen supply once therapy has started.

3.4 STOPPING THERAPY

1. Press Start/Stop to stop therapy.

If using supplemental oxygen, turn off the oxygen supply before turning off therapy on the device.

The screen below will appear:



Your device will then scroll through your therapy data screens. See section 4.1.1 - Therapy Data for more information on these screens.

2. Remove your mask.



Note: If Auto Start/Stop is activated, the device will automatically stop therapy after a short period of time whenever you remove your mask.

To reduce condensation, please keep the device plugged in and switched on at the power supply after stopping therapy.

3.5 STAND-BY MODE

The device will enter stand-by mode after 30 seconds if no button has been pressed on the device.

The display screen light will dim but will remain visible to show that your device is still powered on.

Press **Down** , **Up** , **OK** , or **Menu**  to wake up the device.

3.6 COMFORT SETTINGS

3.6.1 Ramp

Ramp works by gradually increasing to your prescribed pressure over a 20-minute period.

To start Ramp:

Press and hold **Start/Stop**  for 3 seconds until **Ramping**  appears on the display screen:



If you need to restart Ramp, press and hold **Start/Stop**  for 3 seconds until **Restarting**  appears on the display screen.



3.6.2 Humidity

Humidification is the process by which moisture is added to the air you breathe.

You can set the humidity level from 0 (all droplets are transparent) to 7 (all droplets are shaded).



To use humidity, you will need to fill your water chamber daily with water and ensure the humidity level is at least 1 (one droplet shaded).

To adjust humidity at any time:

1. Press **Down** , **Up** , or **Menu** .
2. Press **Down**  or **Up**  to change the level of humidity.

The device will save your changes and time out after a period of no interaction. Alternatively, you can exit this setting by pressing **Menu**  until you reach the previous screen.

Note: Fill your water chamber daily with water.

The default humidity level is 5.



If you are using your device without water in the water chamber, or where low power consumption is required, set the humidity level to 0.

3.6.3 Expiratory relief

Expiratory relief reduces the pressure when you breathe out, and returns to your prescribed pressure when you breathe in.

How to set the expiratory relief level:



1. Press **Menu**  to scroll to the “Expiratory relief” setting.
2. Press **Down**  or **Up**  to change the level of expiratory relief:
 - Off (no circles shaded)
 - Low (1 circle shaded)
 - Medium (2 circles shaded)
 - High (3 circles shaded)



Note: Expiratory relief may be restricted by your healthcare provider.

3.6.4 SensAwake™

We all experience subconscious waking during the night. When this happens, SensAwake will provide pressure relief to help ease your return to sleep.

How to turn SensAwake on or off:



1. Press **Menu**  to scroll to the “SensAwake” setting.
2. Press **Down**  or **Up**  to move between “ON” and “OFF”.



Note: SensAwake may be restricted by your healthcare provider.

3.6.5 Auto Start / Stop

Auto Start / Stop enables the CPAP to automatically start therapy whenever you breathe into your mask, and stop therapy after removing your mask.

How to turn Auto Start / Stop on or off:



1. Press **Menu**  to scroll to the “Auto Start / Stop” setting.
2. Press **Down**  or **Up**  to move between “ON” and “OFF”.

Note: Auto Start / Stop may be restricted by your healthcare provider.





4. VIEWING YOUR THERAPY DATA

4.1 VIEW YOUR THERAPY DATA ON YOUR DEVICE

Your device records your therapy data for the last night, last 7 days, and last 30 days, which you can view at any time.

How to view your therapy data on your device:



1. Press **Menu**  to scroll to “My Data”.
2. Press **Down**  or **Up**  to move between the following options:
 - “D” – Day (last night’s therapy data).
 - “W” – Week (average over the last 7 days of therapy data).
 - “M” – Month (average over the last 30 days of therapy data).
3. Press **OK**  to view the range of therapy data you would like see.

The device will automatically scroll through the following therapy data:

Note: If you would like to bypass this automated scrolling, press **Menu**  to scroll through the data screens manually.

4.1.1 Therapy Data:

THERAPY HOURS



Day View: Displays the number of hours that you used your device last night.

Week View: Displays the average number of hours that you used your device over the last 7 days.

Month View: Displays the average number of hours that you used your device over the last 30 days.

MASK LEAK



Day View: Indicates whether the leak from your mask last night was “NORMAL” or “HIGH”.

Week View: Indicates whether, on average, the leak from your mask was “NORMAL” or “HIGH” over the last 7 days.

Month View: Indicates whether, on average, the leak from your mask was “NORMAL” or “HIGH” over the last 30 days.

Apnea Hypopnea Index (AHI)



Day View: Displays the average number of airway breathing events you had per hour last night.

Week View: Displays the average number of airway breathing events you had over the last 7 days.

Month View: Displays the average number of airway breathing events you had over the last 30 days.

Note: *The AHI screen may be restricted by your healthcare provider. The device-reported AHI is an estimate based on flow, and therefore should not be used for diagnosis of OSA or in isolation for titration or clinical management.*

4.2 VIEW YOUR THERAPY DATA ON THE SLEEPSTYLE APP

Your SleepStyle+ device allows you to view your therapy data on the SleepStyle App*. The SleepStyle App uses Bluetooth wireless technology to communicate with your device.

The SleepStyle App is compatible with iPhone and Android.

You can download the SleepStyle App, available on the Apple App Store or on Google Play™ for Android™.

**Not available in all countries*

To pair your SleepStyle+ device to your mobile device, follow these steps:

1. Turn on your SleepStyle+ device. The device will remain discoverable for a period of 15 minutes. Make sure your mobile device is within range.

Note: *Changing the SleepStyle+ device's Bluetooth setting to “ON” will also make it discoverable for 15 minutes. See below for instructions on how to change your Bluetooth setting.*

2. Open your mobile device's Settings menu and turn on the Bluetooth setting.

Note: *You might need to refer to your mobile phone's user manual for specific instructions on how to turn on the Bluetooth setting.*

3. Open the SleepStyle App and follow the instructions on how to register an account.
4. Follow the instructions in the app on how to pair your mobile device with your SleepStyle+ device.

Your devices should now be paired. The SleepStyle App will stay up-to-date with daily therapy data from your

SleepStyle+ device as long as the Bluetooth setting is turned on for both devices.



You only need to do the pairing once. After you have paired your SleepStyle+ device with your mobile device, it will stay paired and will re-connect automatically until you choose to unpair them.

If you have any problems pairing your SleepStyle+ device to your mobile device, try turning your Bluetooth setting off and on again on your mobile device. If the problem continues, try turning your Bluetooth setting off and on again on your SleepStyle+ device (see below).

How to change your Bluetooth setting:

If the Bluetooth setting is “OFF” on your device, there will be a line through the Bluetooth icon  on your home screen.

To change your Bluetooth setting, follow these steps:

1. From the home screen, hold **Menu**  for 5 seconds.
2. Press **Menu**  to scroll to the 'Bluetooth' setting.



3. Press **Down**  or **Up**  to change the setting. Your selection will flash to confirm your selection.

5. UPLOADING YOUR THERAPY DATA

5.1 MODEM

If your device has a cellular modem, therapy data will automatically upload to your healthcare provider. This will occur as long as your device is plugged in and switched on at the wall. Only your healthcare provider has access to this data.

Note: *The modem is not available in all models. To identify whether your device has a modem, look for the modem symbol  on the device home screen. If your device has a modem, and modem is turned on, ensure that the device is placed at least 20 cm (8 in.) away from your body while in use.*

How to change the modem setting:

Your modem should remain "ON" so that your therapy data will upload to your healthcare provider.

If you need to change your modem setting, follow these steps:

1. From the home screen, hold **Menu**  for 5 seconds.
2. Press **Menu**  to scroll through the screens until you reach the "Cellular Modem" setting.



3. Press **Down**  or **Up**  to change the setting. Your selection will flash to confirm your selection.

If you have turned the modem "OFF", it will turn back on automatically after 3 days.



5.2 F&P INFOUSB™

The InfoUSB automatically stores your therapy data. To ensure your therapy data is recorded to the InfoUSB, you will need to make sure that the InfoUSB is in the InfoUSB port.

If the InfoUSB is connected correctly, the InfoUSB icon  will appear on the device home screen.

You can remove the InfoUSB from the InfoUSB port if requested by your healthcare provider. You can then upload your therapy data, or take your InfoUSB with you when you visit them next, or post the InfoUSB to them.

If your healthcare provider updates your prescription or device settings on the InfoUSB, these changes will automatically transfer to your device when the InfoUSB is next inserted into the InfoUSB port.

Note: *The InfoUSB icon  will not appear on the display screen while it is in stand-by mode. To check that the InfoUSB is connected correctly, press any button to wake up the device. You should see the InfoUSB icon  on screen.*

Cautions

General:

Only use the InfoUSB with the device. Use of any other USB drives may cause data corruption. Do not attempt to change the directories or view the data without software distributed or designed for use with the device.

5.2.1 SleepStyle website

You can easily upload your therapy data for viewing on the SleepStyle website. This information will also be accessible by your healthcare provider.

1. Remove the InfoUSB from your device and insert it into the USB port of a computer

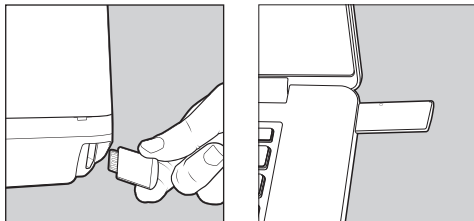

2. Install InfoUSB application

From the Mac App Store

Launch the Mac App Store and search for the InfoUSB app. Install this free application. Upon successful installation, open Launchpad and then open the InfoUSB app.

Note: A Mac running OS X 10.8 or later with a USB port and an internet connection is required.

From the Windows® Store

Launch the Windows Store and search for the InfoUSB app. Install this free application. Upon successful installation, open the app.

Note: A PC or tablet running Windows 8 or later with a USB port and Intranet connection is required.

From the InfoUSB

If you cannot access the Windows Store, click on the Start button and open "My Computer". Navigate to the drive called "FPHCARE". Open this folder and double-click on the Setup.exe file. Follow the on-screen instructions.

Note: A PC running a Windows operating system with a USB port and an internet connection is required.

3. Data transfer

Upon detection of an InfoUSB in your computer, you will be asked to enter your Date of Birth. Enter your Date of Birth and select the Upload button. Ensure that your computer is connected to the internet for successful data transfer to your healthcare provider.

4. Confirmation

After the data has been sent successfully, a confirmation message will appear. If your prescription is updated, you will also see the message "Your healthcare provider has updated your prescription."

5. Future data transfer

Remove the InfoUSB from your computer and place it back into the InfoUSB port of your device. You can now use your device.

The next time you need to upload your therapy data to your healthcare provider, simply insert the InfoUSB into your computer. The message in Step 3 above will automatically appear.

6. CARING FOR YOUR DEVICE

6.1 DISASSEMBLY FOR CLEANING

BREATHING TUBE

1. Hold the elbow of your breathing tube and gently pull it away from the device.

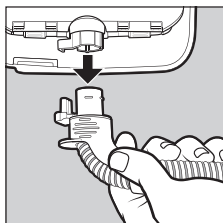

ThermoSmart breathing tube

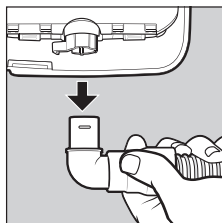

Standard breathing tube

2. Hold both the mask end of the tube and the mask swivel and gently pull them apart.

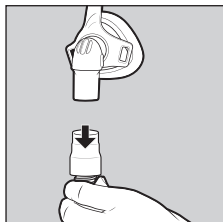

WATER CHAMBER AND CHAMBER SEAL

1. Press the lid latch and open the device lid.
2. Take the water chamber out of the device.
3. Remove the chamber seal from the top of the water chamber and put aside.
4. Lift the tab on the side of the water chamber and lift the chamber lid to open.

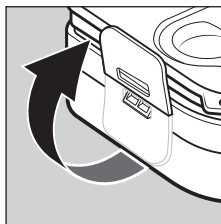
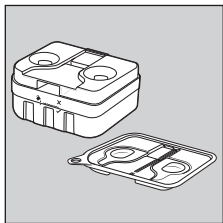
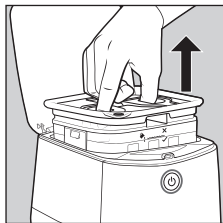

OUTLET SEAL

1. Grip the outlet seal tab.
2. Gently pull the outlet seal out of the device.

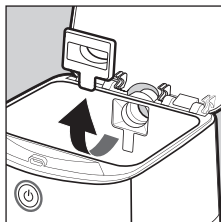

6.2 CLEANING YOUR DEVICE AND ACCESSORIES AT HOME

Cleaning your device and accessories can help extend their life and ensure that you continue to receive effective therapy. The device humidified air path including the chamber, chamber seal, outlet seal and breathing tube can become contaminated with body fluids or by contaminants carried by expired breathing gases. Below is information on when and how to clean the device and accessories. Refer to your mask's user instructions on how to clean your mask.

⚠ Warnings

To avoid electric shock:

Do not use bleach, alcohol, or cleaners with citrus or other natural oils. These substances may degrade the device and accessories.

To avoid adverse effects:

Do not use ozone or activated oxygen to clean this device. Residual ozone may result in adverse respiratory effects such as irritation of the nose, throat and lungs.

To avoid contamination with infectious agents:

Do not share the device, or any used associated spares and consumables, with other users.

To avoid incorrect therapy:

Only clean the device and accessories according to the cleaning instructions below.

⚠ Cautions

General:

Replace the device and accessories if there is any sign of cracking, deformation, discoloration or leaking. It is recommended that you inspect the device, breathing tube, water chamber, chamber seal, outlet seal, air filter and elbow, on a regular basis after cleaning. See section 6.4 – *Replacement Parts*.

Do not use ozone or activated oxygen as it can degrade the device and accessories.

6.2.1 Wash after each use

The following accessories should be cleaned after each use:

- Breathing tube
- Water chamber
- Chamber seal

⚠ Warnings

To avoid incorrect therapy:

Do not clean or disinfect the ThermoSmart breathing tube with hot water. This may cause deformation of the tube and reduce therapeutic pressure.

1. Hand-wash the water chamber, chamber seal, breathing tube and elbow in a tub of warm, soapy water with a mild dishwashing detergent. Ensure that all visible soil is removed.
2. Rinse the water chamber, chamber seal, breathing tube and elbow thoroughly in a tub of clean water for 30 seconds. Ensure that all soap residue has been removed.
3. Repeat the rinsing process again, using clean water.
4. Hang the breathing tube, with both ends pointing to the floor, to dry away from direct sunlight or heat e.g. heated towel rails.
5. Leave the water chamber, chamber seal and elbow to dry out of direct sunlight or heat.

Note: *The elbow and the standard breathing tube need to be separated when washing after each use. If dirt remains inside the breathing tube after rinsing, use a soft, non-metallic brush to remove it. Rinse the tube again. If the dirt cannot be removed, the breathing tube should be replaced.*

The use of distilled water is recommended during therapy to reduce mineral deposits and stains. Should mineral deposits occur, you can reduce these by soaking the water chamber for 10 minutes in a solution of 1 part white vinegar to 2 parts water. Empty the solution and rinse thoroughly with clean water. Repeat the rinsing process again, using clean water. Leave to dry out of direct sunlight or heat before reassembling.

6.2.2 After 7 days' use

The device and accessories below should be washed after 7 days' use:

- Outlet seal
- Elbow
- Device

Outlet seal and elbow

1. Disconnect the elbow from the standard breathing tube.
2. Hand-wash the outlet seal and elbow in a tub of warm, soapy water with a mild dishwashing detergent. Ensure that all visible soil is removed.
3. Rinse the outlet seal and elbow thoroughly in a tub of clean water for 30 seconds. Ensure that all soap residue has been removed.
4. Repeat the rinsing process again, using clean water.
5. Leave to dry out of direct sunlight or heat.
6. Reconnect the elbow to the standard breathing tube.

Device

1. Turn the device off at the power supply, then remove the power cord from the rear of the device.
2. Wipe the exterior and chamber housing of the device with a clean, damp (not dripping wet) cloth and warm, soapy water using a mild dishwashing detergent.
3. Leave to dry out of direct sunlight or heat.

⚠ Warnings

To avoid electric shock:

- Do not pull on the power cord as it may become damaged.
- Do not immerse the device in water or any other liquid.

Dishwashing

Once every 7 days, you can clean the water chamber, chamber seal and outlet seal in a domestic dishwasher. Place the water chamber on the top shelf of the dishwasher and ensure the chamber seal and outlet seal are placed in a secure location.

6.3 REASSEMBLY OF THE DEVICE

Once the parts you have cleaned are dry, you can reassemble the parts.

BREATHING TUBE

1. Hold the elbow end of the breathing tube and push it into the air outlet of the device.

Note: If you have a ThermoSmart breathing tube, make sure the electrical connectors on the elbow click into position with the ThermoSmart connection.

2. Holding the mask and the other end of the breathing tube, push the mask swivel firmly into the breathing tube.

OUTLET SEAL

Hold the tab on the outlet seal and push it into the chamber housing inlet. Ensure the tab is sitting flat against the wall of the chamber.

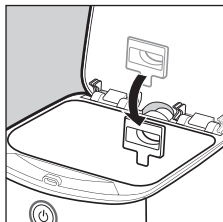

WATER CHAMBER AND CHAMBER SEAL

1. Close the chamber lid. Press the water chamber tab down until it clicks into place.
2. Fill the water chamber with water through either of the filling holes in the top.
3. Secure the chamber seal back onto the water chamber. Ensure it is sitting flat and seals the holes on the chamber lid.
4. Place the water chamber back into the device.

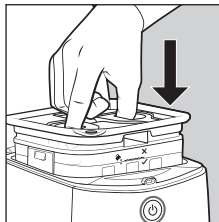
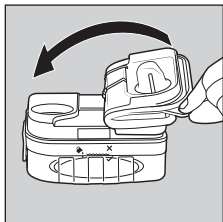
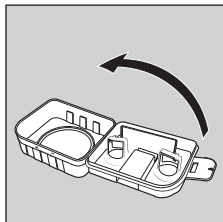

6.4 REPLACEMENT PARTS

900SPS100	Water chamber
900SPS101	Chamber seal
900SSP113	Air filter (single)*
900SSP114	Air filters (2-pack)*
900SSP112	Ultra-fine filter**
900SPS120	ThermoSmart breathing tube***
900SPS121	Standard breathing tube with elbow***
900SPS122	Elbow (for use with a standard breathing tube)
900SSP143	Device lid
900SPS141	Outlet seal
900SPS142	Carry bag
900SW101	F&P InfoUSB
900SPS161	Australasian power cord
900SPS160	North American power cord
900HC452	Oxygen/Pressure Port Connector

*The air filter does not include the ultra-fine filter.

**The ultra-fine filter is an optional accessory that can be purchased separately from your healthcare provider. 900SSP112 contains an air filter with 3 ultra-fine filters

*** Applied Parts - to fit 22 mm (0.86 in.) Conical Connector.

⚠ Warnings

To avoid injury:

Do not use breathing tubes, parts and accessories that are not distributed for use with this device or recommended by Fisher & Paykel Healthcare.

General:

Do not use accessories or power cables which are not provided, or recommended, by Fisher & Paykel Healthcare. This could result in increased electromagnetic emissions or decreased electromagnetic immunity.

6.4.1 Air filters

The air filter is located at the rear of the device. Replace the air filter 900SSP113 at least once every 3 months, and the ultra-fine filter 900SSP112 once every month, or more frequently if it becomes blocked with dirt or dust. To replace the air filter, please follow the instructions below.

Warnings

To avoid choking, or inhalation of a foreign object: Do not use the device without the recommended air filter fitted. This will reduce dust or particles entering the device and breathing tube.

1. To remove, hold the device and pull out the air filter housing using your fingers.

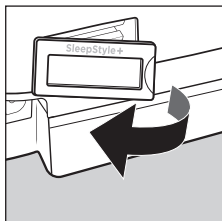

2. If there is an ultra-fine filter in the air filter housing, remove this by holding the air filter housing and pulling out the ultra-fine filter out.

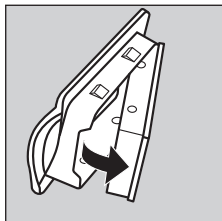

3. If applicable, place an unused ultra-fine filter into the back of the air filter housing.

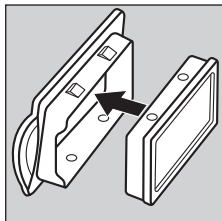

7. TRAVELING WITH YOUR DEVICE

The device has a universal voltage feature that allows it to operate on any domestic AC mains voltage. With the use of the appropriate pin/plug adapter the device can operate in most countries.

Below is a checklist of what to take with you when you travel:

- Carry bag
- SleepStyle+ device
- Water chamber (empty)
- Chamber seal
- ThermoSmart breathing tube or standard breathing tube with elbow
- F&P InfoUSB
- Power cord
- Air filter
- Outlet seal
- F&P SleepStyle+ Use and Care Guide
- Mask

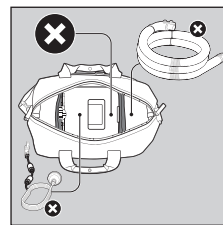
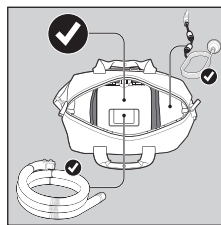

You may also need:

- Extension cord
- Plug adapter

Cautions

To prevent water damage to the device: Empty the water chamber before transporting or packing.

Note: The device is not certified for use on an aircraft. Confirm with your airline whether you can take the device with you as carry-on luggage.

8. SPECIFICATIONS

8.1 SLEEPSTYLE+ DEVICE MODELS AND FEATURES

Device model	SleepStyle+ Auto	SleepStyle+ CPAP
Australasia	SSPAAA	SSPCAA
North America	SSPAAN	

Performance features	
Fully integrated humidifier	Auto-altitude adjustment
ThermoSmart technology**	Leak compensation
Auto-adjusting pressure†	Efficacy reporting
SensAwake	Compliance reporting
Expiratory relief	F&P InfoUSB
Ramp	Bluetooth wireless technology*
Auto Start / Stop	Cellular modem*

Compatible with
F&P SleepStyle App and Web‡



















* Not available in all models.

**The ThermoSmart Breathing Tube is required to activate ThermoSmart.

†SleepStyle+ Auto only.

‡Not available in all countries

8.2 SYMBOL DEFINITIONS

	For safety reasons, refer to the instructions for use		Date of shelf life expiry		Humidity range
	Caution		Type BF applied part		Temperature range
	Consult instructions for use		Non-ionizing electromagnetic radiation	IP 22	Protected against ingress of small objects and water drops
	UL classified mark		Taiwan National Communications Commission (NCC) Certification mark		Do not use if package is damaged
	Fill with water here		Class II equipment	Rx only	Prescription only
	Maximum water level (do not fill above the water line)	REF	Catalogue number		Giteki mark
	Manufacturer	SN	Serial number		Do not discard as regular waste
	Date of manufacture	LOT	Batch code	MD	Medical device
	Regulatory Compliance Mark				

8.3 PRODUCT SPECIFICATIONS

Dimensions	144 H x 177 W x 183 D mm (5.7 H x 7.0 W x 7.2 D in.)
Weight	1.7 kg (3.7 lb) Packed Weight (max.): 2.7 kg (5.9 lb)
Performance	Ventilation-mode: CPAP Pressure Range: 4 to 20 cmH ₂ O/hPa (in the unlikely event of fault conditions, pressure limited to <30 cmH ₂ O)

Maximum flow rates STPD*					
CPAP pressure setting (cmH ₂ O)	4	8	12	16	20
Air filter	>145	>150	>150	>135	>115
Ultra-fine filter	>145	>150	>135	>120	>100

*Standard Temperature and Pressure, Dry

Dynamic pressure stability with air filter†					
	BPM ¹	Test pressure			
		4.0 cmH ₂ O	8.0 cmH ₂ O	12.0 cmH ₂ O	16.0 cmH ₂ O
Dynamic pressure stability (cmH ₂ O)	10	+/- 0.5		+/- 0.8	
	15				
	20				

Dynamic pressure stability with ultra-fine filter‡					
	BPM ¹	Test pressure			
		4.0 cmH ₂ O	8.0 cmH ₂ O	12.0 cmH ₂ O	16.0 cmH ₂ O
Dynamic pressure stability (cmH ₂ O)	10	+/- 0.6		+/- 0.8	
	15				
	20				

¹ BPM – Breaths Per Minute

† The air filter does not include the ultra-fine filter.

‡ The ultra-fine filter is an optional accessory that can be purchased separately from your healthcare provider.

Static pressure stability**	
	Auto-adjusting and fixed pressure
Pressure change (cmH ₂ O) at connection port at a pressure setting of 10 cmH ₂ O	± 0.5*

*Stated bias error with 0% linearity error

**Pressure measurement including uncertainty: ± (0.04 cmH₂O + 0.026% of reading)

The pneumatic flow path:

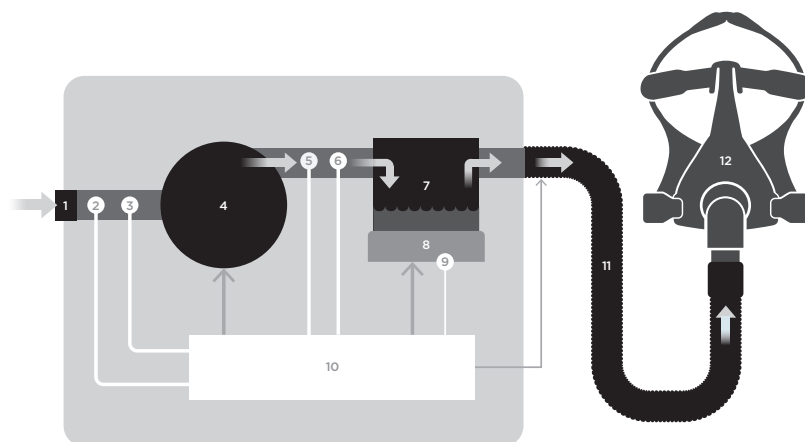

- | | |
|-------------------------------|------------------------------------|
| 1. Air inlet filter | 7. Water chamber |
| 2. Ambient temperature sensor | 8. Heater plate |
| 3. Flow sensor | 9. Heater plate temperature sensor |
| 4. Blower | 10. Control system |
| 5. Relative humidity sensor | 11. Breathing tube |
| 6. Pressure sensor | 12. Mask |

Humidity output in typical conditions

Humidity output	AH ² (mgH ₂ O/L BTPS ³)	
	With ThermoSmart breathing tube	With standard breathing tube
Tested at 23 °C (73.4 °F) ambient temperature		
Humidity level 7	> 23	> 20
Humidity level 6	> 21	> 18
Humidity level 5	> 18	> 15
Humidity level 4	> 17	> 14
Humidity level 3	> 15	> 13
Humidity level 2	> 13	> 10
Humidity level 1	> 10	> 10

Humidifier operating air flow range from 18 to 53 litres per minute.

Humidity output for ThermoSmart breathing tube >12 mgH₂O/L BTPS³ for all conditions as per ISO 80601-2-74.

Humidity output for standard breathing tube >12 mgH₂O/L BTPS³ for ambient temperature above 17 °C (62 °F) as per ISO 80601-2-74.

² AH - Absolute Humidity

³ BTPS - Body Temperature Pressure Saturated

Expiratory Relief	
Expiratory relief level	Pressure reduced during expiration (cmH₂O)
Off	0 cmH ₂ O
Low	1 cmH ₂ O
Medium	2 cmH ₂ O
High	3 cmH ₂ O

Electrical ratings		
Rated supply voltage	Rated current input	Rated supply frequency
100–115 V	1.2 A (2.5 A max.)	50–60 Hz
220–240 V	1.1 A (2.3 A max.)	50–60 Hz

Outlet air temperature	Maximum = 38 °C (100 °F)	
Noise level	Sound pressure level 28 ±1.5 dBA; average sound power level <35 dBA	
Water chamber volume	380 mL up to the maximum water-level line	
Standards compliance	ISO 80601-2-70; ISO 80601-2-74 Category 2; IEC 60601-1; IEC 60601-1-2; IEC 60601-1-11; IEC 62304 Software safety class B; ISO 10993-1; ISO 18562-1	
FCC compliance	<p>This device has been tested and found to comply with the limits for a Class B digital device, pursuant to part 15 of the FCC Rules. These limits are designed to provide reasonable protection against harmful interference in a residential installation. This device generates, uses and can radiate radio frequency energy and, if not installed and used in accordance with the instructions, may cause harmful interference to radio communications. However, there is no guarantee that interference will not occur in a particular installation. If this device does cause harmful interference to radio or television reception, which can be determined by turning the device off and on, the user is encouraged to try to correct the interference by one or more of the following measures:</p> <ul style="list-style-type: none"> • Reposition or relocate the receiving antenna. • Increase the separation between the device and receiver. • Connect the device into an outlet on a circuit different from that to which the receiver is connected. • Consult your healthcare provider or your Fisher & Paykel Healthcare representative for help. 	
Data recording	The InfoUSB will store up to 5 years of summary efficacy data, 365 days of detailed efficacy data, and 140 hours of high-resolution pressure, leak and flow data. Without an InfoUSB, the device's internal memory is capable of storing up to 1 year of summary efficacy data, 30 days of detailed efficacy data, and 20 hours of high-resolution pressure, leak and flow data.	
Service life	Device	5 years
	Breathing tubes	12 months
	Water chamber	12 months
	Air filter	3 months
	Ultra-fine filter	1 month
General	The patient is an intended operator.	

8.4 CLASSIFICATIONS

Mode of operation	Continuous operation
Electric shock protection	Type BF
Ingress protection	IP22

8.5 OPERATING CONDITIONS

Ambient temperature	5 to 35 °C (41 to 95 °F)
Humidity	15 to 90% RH
Altitude	0 to 3,000 m (0 to 9,000 ft)

Cautions

General:

Only use the device within the operating conditions specified, otherwise the performance of the device could be compromised.

Note: Above 1,500 m (4,500 ft) the maximum operating pressure will be reduced at high flow rates.



8.6 STORAGE AND TRANSPORT CONDITIONS

The device should always be stored and transported within the following temperatures and humidity ranges.

Temperature	-10 to 60 °C (14 to 140 °F)
Humidity	15 to 90% RH

Note: Following storage and transportation, allow 30 minutes for the device to adjust to the operating conditions before use.

8.7 DISPOSAL INSTRUCTIONS

	<p>Device disposal instructions</p> <p>This device contains electronics and a lithium battery. Please do not discard as regular waste. Dispose of electronics and lithium battery according to local guidelines.</p>
	<p>Accessory and spare part disposal instructions</p> <p>Dispose of breathing tube, water chamber, and other spare parts according to local guidelines. Place the breathing tube and water chamber in a waste bag at the end of use and discard with normal waste.</p>

8.8 SERVICING

Warnings

General:

This device is not repairable and does not contain any repairable parts. Please refer queries relating to the device or accessories to your healthcare provider.

This device contains a non-replaceable lithium coin cell battery that is hazardous. Keep away from children. Seek immediate medical attention if it is suspected the button cell battery has been swallowed or placed inside any part of the body, as severe or fatal injuries may occur within 2 hours.

The device does not require preventative maintenance.

8.9 WARRANTY STATEMENT

Fisher & Paykel Healthcare warrants that the device (excluding consumable items forming part of the CPAP delivery system), when used in accordance with the instructions for use, shall be free from defects in workmanship and materials and will perform in accordance with Fisher & Paykel Healthcare's official published product specifications for a period of 2 years from the date of purchase by the end-user. This warranty is subject to the limitations and exceptions set out in detail here:

www.fphcare.com/sleep-apnea/cpap-devices/warranty-cpap/

9. TROUBLESHOOTING

If you feel that your device is not operating correctly, please refer to the following suggestions. If the problem persists, please consult your healthcare provider. Do not attempt to repair the device yourself.







Warnings

To avoid electric shock:

- Do not modify the device or accessories.
- Do not take apart the device. Taking the device apart, for example by unscrewing the underside of the device, will damage pressure seals and electrical components.

9.1 DEVICE TROUBLESHOOTING

Problem	Solution
My therapy won't start, and there is no display on the display screen.	The power cord may not be plugged in correctly. Solution: Push the power cord connector firmly to confirm it is inserted correctly into the power supply and into the rear of the device.
	Has there been a storm, power outage, or power surge? Solution: Check your circuit breaker or fuse, and reset as required. If the display screen does not turn on, return the device to your healthcare provider.
My therapy won't start, but there is a display on the display screen.	There may be water in the blower, preventing it from starting. Solution: Turn off at the power supply and unplug the device. Remove the water chamber. Keep the device lid open and tip the device upside down to clear the water from the device. Place the water chamber back in the device. Restart the device.
	Is there an error message on the display screen? Solution: Refer to section 9.2 - <i>Error messages on SleepStyle+ screen.</i>
The pressure is fluctuating or insufficient air is being delivered from the device.	Your mask may not be fitted correctly, causing leaks. Solution: Ensure your mask is correctly fitted. Refer to your mask's user instructions for fitting instructions, or contact your healthcare provider.
	There may be water in the breathing tube. Solution: Disconnect the breathing tube and hang with both ends pointing to the floor until all water in the breathing tube has been cleared.
	The device lid may not be closed correctly, the chamber seal may not be fitted to the water chamber correctly, or the outlet seal is missing. Solution: Ensure the outlet seal and water chamber with the chamber seal are in the device. Refer to section 6.3 - <i>Reassembly of the device</i> for detailed instructions on reassembly of these parts.
The device is noisy.	Air may be leaking out of the device or breathing tube. Solution: Make sure the device lid has been closed properly, the breathing tube and mask are connected correctly, and there are no air leaks or condensation in the breathing tube.
	If the noise is changing while you breathe, this is because the device adjusts the motor speed to maintain the correct pressure as you breathe in and out. This is normal behavior.
The base of the device is warm to the touch even though the device isn't being used.	This is normal and should not cause concern. In stand-by mode, the device consumes approximately 5 W of power. This may cause the feeling of warmth.

Problem	Solution
There is a build-up of water on the heater-plate.	<p>When therapy has stopped, the device will cool, which may cause condensation to form on the heater-plate.</p> <p>Solution: To reduce condensation, please keep the device plugged in and switched on at the power supply after stopping therapy. Before each use, remove the water chamber and dry the chamber housing of the device with a cloth. If the water build-up becomes excessive, please contact your healthcare provider.</p>
I don't think my humidifier is working.	<p>The humidity level may be incorrect.</p> <p>Solution: Check if the humidity level is above 0. See section 3.6 – <i>Comfort Settings</i> for more information on changing the humidity setting.</p>
	<p>The water chamber may be empty.</p> <p>Solution: Check if there is water in the water chamber. See section 2.2 – <i>Setting Up Your Device</i> for instructions on filling your water chamber.</p>
	<p>The ThermoSmart breathing tube is not connected to the device correctly.</p> <p>Solution: Remove the ThermoSmart breathing tube from the device and re-connect. Make sure that the electrical connectors click together with the ThermoSmart connection. When connected correctly, the ThermoSmart icon  will appear on your home screen.</p>
The ThermoSmart icon has a line through it  or there is a gap where this icon should appear.	<p>The tube may not be connected correctly or there may be an error with the ThermoSmart breathing tube. You will still be treated and get humidity, but it may not be optimal.</p> <p>Solution: Remove the ThermoSmart breathing tube from the device and re-connect. Make sure that the electrical connectors click together with the ThermoSmart connection. When connected correctly, the ThermoSmart icon  will appear on your home screen.</p>
	<p>You may be using a standard breathing tube. Consult your healthcare provider for more information.</p>
The InfoUSB icon has a line through it  or there is a gap where this icon should appear.	<p>The InfoUSB may not be connected correctly or there may be an error with the InfoUSB. You will still be treated, but your therapy data may not be recorded to the InfoUSB.</p> <p>Solution: Remove the InfoUSB from the InfoUSB port and re-insert. When connected correctly, the InfoUSB icon  will appear on your home screen.</p>
The modem icon has a line through it  .	<p>Modem is turned “Off” on your device or the modem has failed to connect. You will still be treated, but your therapy data may not be uploaded to your healthcare provider.</p> <p>Solution: Turning the modem off and on again on your device may resolve connectivity issues. Refer to section 5.1 – <i>Modem</i> for instructions on changing your modem setting.</p>
The Bluetooth icon has a line through it  .	<p>The Bluetooth setting is turned “Off” on your device or there may be an error with the Bluetooth setting. You will still be treated, but your therapy data may not be available on your SleepStyle app.</p> <p>Solution: Turning the Bluetooth setting off and on again on your mobile device may resolve connectivity issues. Refer to section 4.2 – <i>View your therapy data on the SleepStyle App or website</i> for instructions on changing your Bluetooth setting.</p>

9.2 ERROR MESSAGES ON SLEEPSTYLE+ SCREEN

If a fault is detected with your device or its accessories, an error message will appear on the display screen. Identify the error code in the ranges specified below and follow the appropriate corrective action. If the error persists or reoccurs, please consult your healthcare provider. Do not attempt to repair the device yourself.

Error codes between	Solution
100–199	Your device may not be able to provide effective therapy. Your device may have shut down or may not be able to provide your prescribed pressure. Solution: Turn the power off and on at the power supply to restart the device.
400–499	Humidity may have been disabled. Your device is still safe to use without humidity. You will still be treated at your prescribed pressure. Solution: Turn the power off and on at the power supply to restart the device.
510 or 512	There may be a problem with your ThermoSmart breathing tube. Your device is still safe to use. You will still be treated and get humidity, but it may not be optimal. Solution: Try re-connecting your ThermoSmart breathing tube. When connected correctly, the ThermoSmart icon  will appear on the home screen. Alternatively, turn the power off and on at the power supply to restart the device.
500–599 (excluding 510 or 512)	The ThermoSmart breathing tube may have been disabled. Your device is still safe to use. You will still be treated and get humidity, but it may not be optimal. Solution: Turn the power off and on at the power supply to restart the device.

F&P SleepStyle+, SensAwake, ThermoSmart, InfoUSB and F&P InfoUSB are trademarks of Fisher & Paykel Healthcare Ltd.

The Bluetooth® word mark and logos are registered trademarks owned by Bluetooth SIG Inc. and any use of such marks by Fisher & Paykel Healthcare is under license. Other trademarks and trade names are those of their respective owners.

Android and Google Play are trademarks of Google Inc.

“Made for iPhone” means that an electronic accessory has been designed to connect specifically to iPhone, and has been certified by the developer to meet Apple performance standards. Apple is not responsible for the operation of this device or its compliance with safety and regulatory standards. Please note that the use of this accessory with iPhone may affect wireless performance. Apple, OS X, Mac and iPhone are trademarks of Apple Inc., registered in the U.S. and other countries. App Store is a service mark of Apple Inc., registered in the U.S. and other countries. The trademark “iPhone” is used with a license from Apple Inc.

Windows is either a registered trademark or trademark of Microsoft Corporation in the United States and/or other countries.

For patent information, see www.fphcare.com/ip.

 Fisher & Paykel Healthcare Ltd, 15 Maurice Paykel Place, East Tamaki, Auckland 2013, PO Box 14 348 Panmure, Auckland 1741, New Zealand
Tel: +64 9 574 0100 Email: info@fphcare.co.nz Web: www.fphcare.com

 **Australia (AU)** (Sponsor) Fisher & Paykel Healthcare Pty Ltd, 19-31 King Street, Nunawading, Melbourne, Victoria 3131. Tel: +61 3 9871 4900

Brazil (BR) Fisher & Paykel do Brasil, Rua Sampaio Viana, 277 cj 21, Paraíso, 04004-000, São Paulo – SP, Brazil Tel: +55 11 2548 7002

China (CN) 代理人/售后服务机构: 费雪派克医疗保健 (广州) 有限公司, 广州高新技术产业开发区科学城科丰路31号G12栋301号 电话:

+86 20 32053486 **France (FR)**  Fisher & Paykel Healthcare SAS, 10 Av. du Québec, Bât F5, BP 512, Villebon-sur-Yvette, 91946

Courtboeuf Cedex, France Tel: +33 1 6446 5201 Email: c.s@fphcare.fr **Germany (DE)** Fisher & Paykel Healthcare GmbH, Wiesenstrasse 49,

73614 Schorndorf, Germany Tel: +49 7181 98599 0 **Hong Kong (HK)** Tel: +852 2116 0032 **India (IN)** Tel: +91 80 2309 6400 **Japan (JP)**

Tel: +81 3 5117 7110 Fax: +81 3 5117 7115 **Korea (KR)** Tel: +82 2 6205 6900 **Mexico (MX)** Tel: +52 55 9130 1626 **Poland (PL)** Fisher & Paykel

Healthcare Poland Sp. z o.o., Pl. Andersa 7, 61-894 Poznań, Poland Tel: +48 664 846 464 **Russia (RU)** Tel: +7 495 782 21 50 **Switzerland (CH)**

 Fisher & Paykel Healthcare GmbH, Säntisstrasse 2, 9501 Wil / SG, Switzerland Tel: 0800 83 47 63 **Taiwan (TW)** Tel: +886 2 8751 1739

Turkey (TR) İthalatçı Firma: Fisher Paykel Sağlık Ürünleri Ticaret Limited Şirketi, İletişim Bilgileri: Ostim Mahallesi 1249. Cadde No:6,

Yenimahalle, Ankara, Türkiye 06374, Tel: +90 312 354 34 12 **UK (GB)**  Fisher & Paykel Healthcare Ltd, Unit 16, Cordwallis Park,

Clivemont Road, Maidenhead, Berkshire SL6 7BU, UK Tel: 0800 132 189 **USA (US)/Canada (CA)** Tel: 1800 446 3908 or +1 949 453 4000

Austria (AT) Tel: 0800 29 31 23 **Benelux (BE NL LU)** Tel: +31 40 216 3555 **Denmark (DK)** Tel: +45 70 26 37 70 **Finland (FI)**

Tel: +358 9 251 66 123 **Ireland (IE)** Tel: 1800 409 011 **Italy (IT)** Tel: +39 06 7839 2939 **Norway (NO)** Tel: +47 21 60 13 53 **Spain (ES)**

Tel: +34 902 013 346 **Sweden (SE)** Tel: +46 8 564 76 680